

# AS8D99VS

**STANDARD MATERIALS AND CONSTRUCTION**

- FRAME:** Head and Sill: .125" thick (nominal) formed aluminum alloy 6063-T52/T6.  
Jams: .081" thick (nominal) extruded aluminum alloy 6063-T52/T6.  
 Frame is welded construction.
- BLADE:** .24" thick (nominal) at edges, reducing to .063" thickness (nominal) at midpoint of profile. Blades approximately 1.25" on centers.
- MULLION:** Exposed, vertical with 1.75" x .08" 6063-T52/T6 extruded aluminum cover (multiple panels only). Exposed, horizontal.
- FINISH:** Mill

**OPTIONS**

- Finish - Baked Enamel, Kynar, Anodize  
 Screens - 1/2" flattened aluminum (.051" thick),  
 -or- 1/2" sq. mesh, intermediate double-crimped aluminum wire, .063" dia.,  
 -or- 19/16 mesh, .011" dia. aluminum wire, insect screen,  
 and a variety of other bird and insect screens.  
 Extended Sill - .063" formed aluminum

**NOTES**

- Nominal deductions will be made to the opening size given.
- Approximate shipping weight is 4.5 lbs./sq.ft.

**LOUVER SIZES**

Min Panel	Max Single Panel
12"W x 18"H	48"W x 96"H

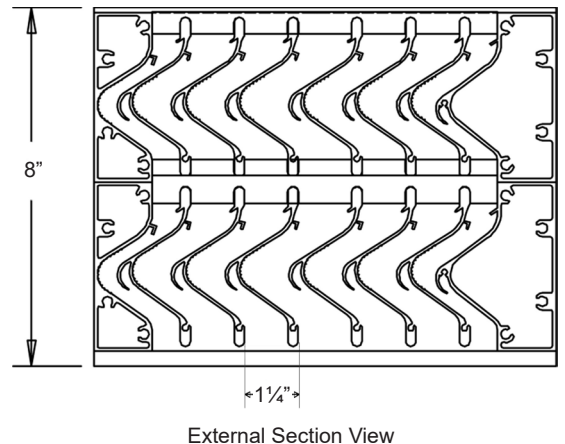
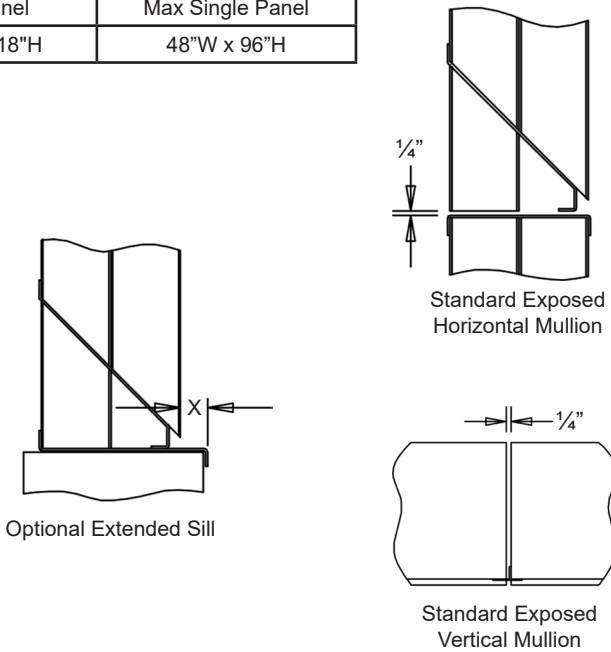
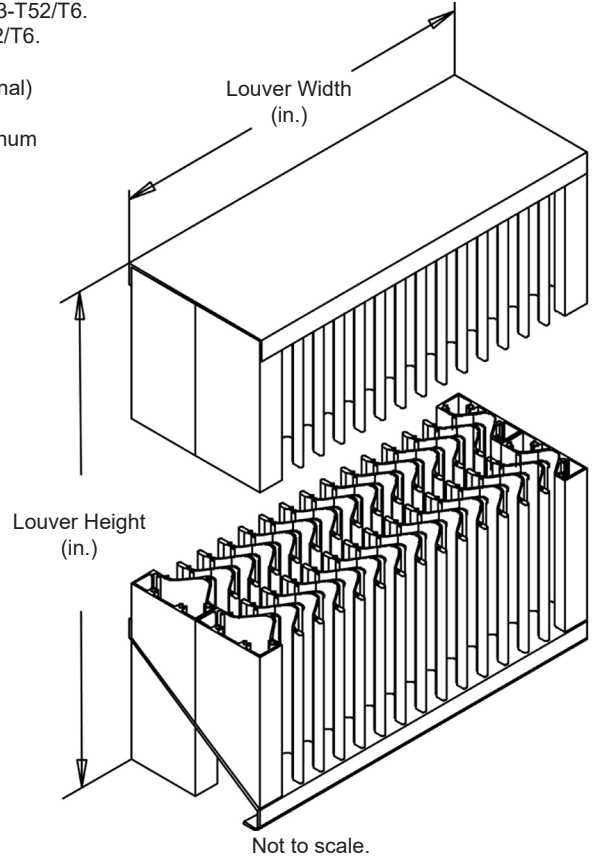

In the interest of product development, Airline Louvers reserves the right to make changes without notice.

										
Item #	Qty	Width	Height	Width	Height	Mullion	Type	Location		
		Opening Size		Louver Size			Screens			<b>Union Made</b>
<b>Arch. / Eng. :</b>						<b>EDR:</b>		<b>ECN:</b>		<b>Job:</b>
<b>Contractor:</b>										
<b>Project:</b>						<b>Date:</b>		<b>DWN:</b>		<b>DWG:</b>

# AS8D99VS

### PERFORMANCE DATA

Pressure Drop: .65 in. w.g. (161.9 Pa) at 1250 fpm (6.4 m/s) and 9667 scfm (4.6 scm/s)  
 Free Area: 4.41 sq.ft. (0.410 m<sup>2</sup>) = 27.56% for 48"W x 48"H (1.2m x 1.2m) sample tested in accordance with AMCA Standard 500-L.

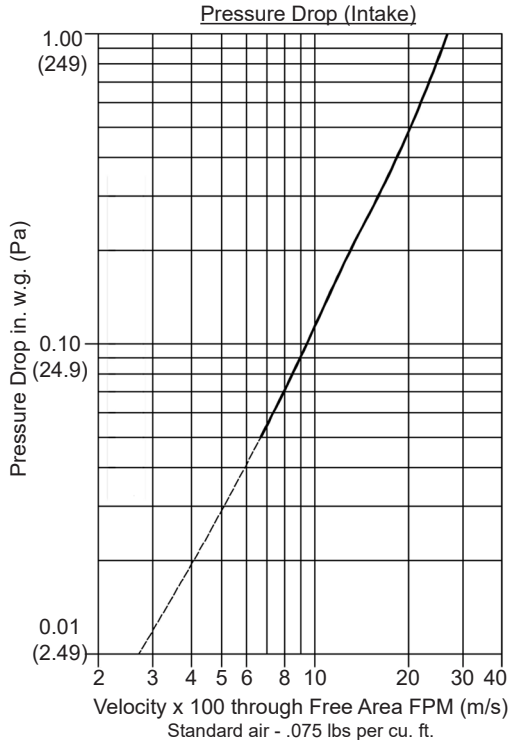

Pressure Drop & Free Area Velocity

Pressure Drop	.10 in. w.g. (24.91 Pa)	.20 in. w.g. (49.82 Pa)	.30 in. w.g. (74.73 Pa)
Free Area Velocity	940 FPM (4.78 m/s)	1300 FPM (6.6 m/s)	1600 FPM (8.13 m/s)

Ratings do not include effects of a screen.  
 Test based on 48" x 48" sample size  
 per AMCA Standard 500-L, Figure 5.5.

Free Area sq.ft. (sq. meters)

		Width in. (mm)								
		12" (305)	24" (610)	36" (914)	48" (1219)	60" (1524)	72" (1829)	84" (2134)	96" (2438)	
Height in. (mm)	18" (457)	0.18 (0.016)	0.41 (0.038)	0.65 (0.060)	0.88 (0.081)	1.12 (0.104)	1.35 (0.125)	1.58 (0.146)	1.82 (0.169)	1 Section
	24" (610)	0.32 (0.030)	0.73 (0.068)	1.17 (0.109)	1.58 (0.147)	2.02 (0.188)	2.43 (0.226)	2.85 (0.265)	3.28 (0.305)	
	36" (914)	0.60 (0.056)	1.39 (0.129)	2.21 (0.206)	3.00 (0.278)	3.82 (0.355)	4.61 (0.428)	5.39 (0.501)	6.22 (0.578)	
	48" (1219)	0.89 (0.082)	2.04 (0.190)	3.26 (0.303)	4.41 (0.410)	5.63 (0.523)	6.78 (0.630)	7.93 (0.737)	9.15 (0.850)	
	60" (1524)	1.17 (0.109)	2.69 (0.250)	4.30 (0.400)	5.83 (0.541)	7.43 (0.690)	8.96 (0.832)	10.48 (0.973)	12.09 (1.123)	2 Sections High
	72" (1829)	1.46 (0.135)	3.35 (0.311)	5.35 (0.497)	7.24 (0.673)	9.24 (0.858)	10.63 (0.988)	12.52 (1.16)	14.42 (1.34)	
	84" (2134)	1.74 (0.162)	4.00 (0.372)	6.39 (0.594)	8.65 (0.804)	11.04 (1.03)	12.71 (1.18)	14.97 (1.39)	17.23 (1.60)	
	96" (2438)	2.03 (0.188)	4.66 (0.433)	7.43 (0.691)	10.07 (0.953)	12.48 (1.19)	14.78 (1.37)	17.42 (1.62)	20.05 (1.86)	
		1 Section				2 Sections Wide				